



Electrolux
PROFESSIONAL

**Handling System for Rack Type
Automatic Sorting Table, Dishwashing
Driven with 5 Baskets - Right to Left,
2640mm**

ITEM # _____

MODEL # _____

NAME # _____

SIS # _____

AIA # _____

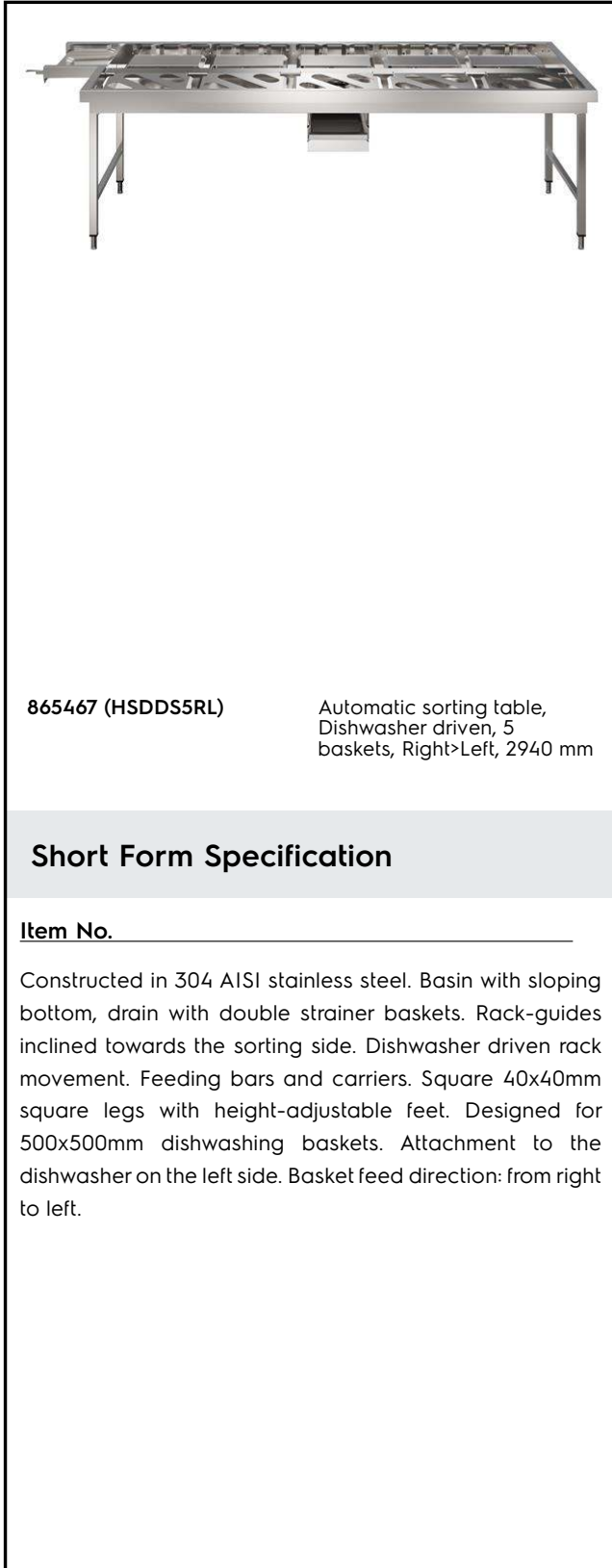

865467 (HSDDS5RL)

Automatic sorting table,
Dishwasher driven, 5
baskets, Right>Left, 2940 mm

Short Form Specification

Item No. _____

Constructed in 304 AISI stainless steel. Basin with sloping bottom, drain with double strainer baskets. Rack-guides inclined towards the sorting side. Dishwasher driven rack movement. Feeding bars and carriers. Square 40x40mm square legs with height-adjustable feet. Designed for 500x500mm dishwashing baskets. Attachment to the dishwasher on the left side. Basket feed direction: from right to left.

Main Features

- "Key holes" and "snap on" system reduces the number of screws needed for fast and easy installation.
- Designed to transport 500x500 mm dishwashing baskets.
- Stacking tables for 7 and 8 baskets on request.
- Optional extras: basin wash nozzles for cleaning the basin.
- Driven by the dishwasher.

Construction

- All surfaces smooth with polished finish.
- Thick welded flanges for sturdy connection between the units.
- Sloping bottom of the table grants a smooth and rapid drainage.
- Stainless steel strainer baskets easy to remove.
- Rack-guides inclined towards the basin.
- Double filter strainer installed on both sides allow the access from both directions.
- Double stainless steel strainer basket for easy operation.
- Constructed in AISI 304 stainless steel with square 40x40mm tubular construction feet and legs.

Optional Accessories

- Pre-rinse unit (thermostatic mixer and shower) to be mounted on overshell PNC 863136
- Additional waste rack for dishwasher driven and automatic sorting table PNC 863173
- Soaking basin for cutlery rack including lifting device for dishwasher driven sorting table PNC 863230
- Emergency stop kit for Rack Type Dishwasher (not for Basic handling system) PNC 865162
- Basket support for vertical stacking of baskets (to be used with overshell) PNC 865208
- Pre-rinse unit (mixer and shower) PNC 865209
- Double overshell for 5-basket sorting table, 2630 mm PNC 865427
- Overshell for 5-basket sorting table, 2630 mm PNC 865431
- Tray slide for 5-basket sorting table, 2640 mm PNC 865435
- Tray slide fixing brackets (3pcs) PNC 865437
- Grid undershell for 5-basket sorting table PNC 865440
- Pre-wash spray unit, 1500 mm PNC 865443
- Tray slide for sorting table, 500 mm PNC 865444
- Tray slide with waste hole and rubber ring, 500 mm PNC 865445
- Dish scraper PNC 865447
- Water heating kit for wash basin PNC 865449

APPROVAL: _____



Experience the Excellence
www.electroluxprofessional.com

- Foldable tray slide for 5-basket sorting table, 2640 mm PNC 865456
- Retractable pre-rinse unit with fixed thermostatic water mixer, hose length, 14mm PNC 865460
- Brackets to support baskets under the sorting table PNC 865478

Key Information:

External dimensions, Width:	865467 (HSDDS5RL)	2940 mm
External dimensions, Depth:		1110 mm
External dimensions, Height:		910 mm
Net weight:		64 kg
Height adjustment:		50/50 mm
Basket movement:		Right to left
Position to dishwasher:		Loading
Basin material:		Stainless Steel AISI 304 - EN 1.4301

Front

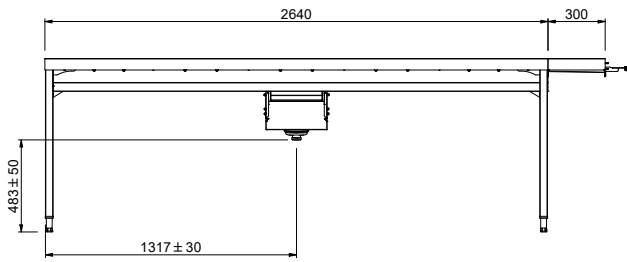

Side

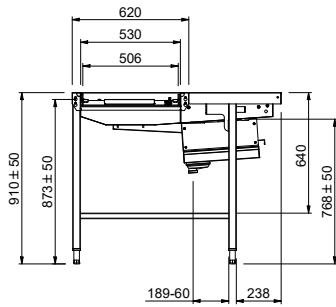

Factory mounted waste rack

D = Drain

Top

